

CONCORD LEVEL AND STAIR RAIL DETAILS

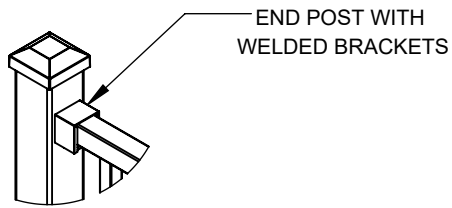

NOTES:
POST INCLUDES BRACKET
COVERS TO HIDE FASTENERS

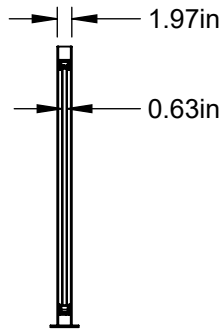

SECTION D-D
SCALE 1 : 26

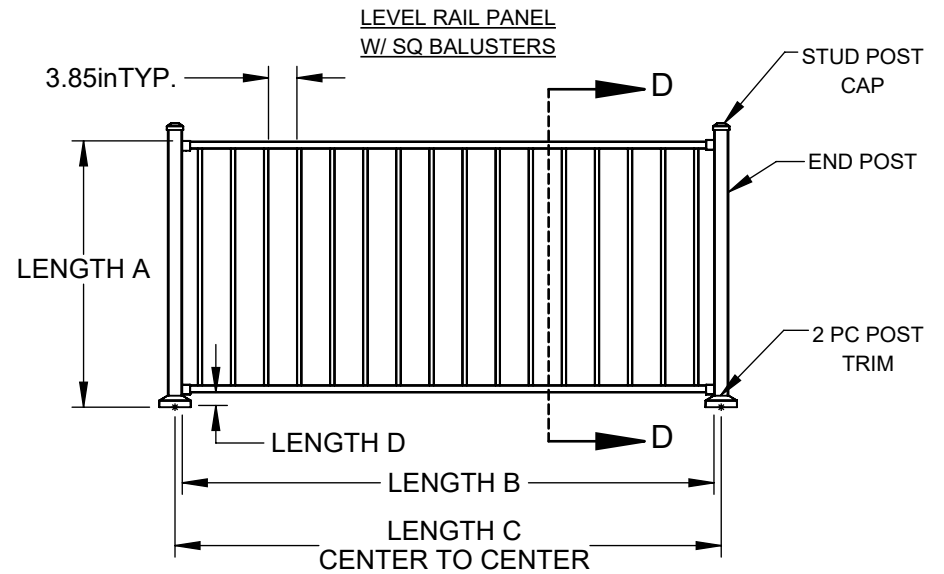

NOTES:

(A) FINISHED RAIL HEIGHT = 36", 38", 42"

(B) PANEL LENGTH = 71.75", 95.75", 119.75"

(C) MAX SPAN = 96.00" X 42 IBC, 96.00" X 36 IRC

(D) BOTTOM SPACE = 1.75", 3.75"

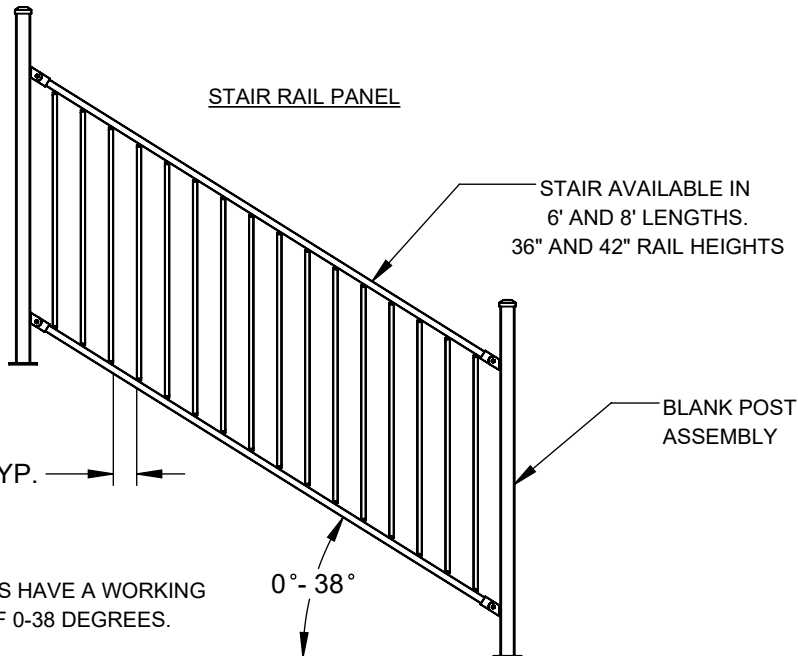

NOTES:
STAIR KITS HAVE A WORKING
RANGE OF 0-38 DEGREES.

THE INFORMATION CONTAINED IN
THIS DRAWING IS PROTECTED BY
COPYRIGHT AND PATENT LAWS
OF THE UNITED STATES AND
OTHER COUNTRIES. ANY
REPRODUCTION IN PART OR AS A
WHOLE WITHOUT WRITTEN
PERMISSION IS PROHIBITED.

| TOLERANCES | | | | | | |
|----------------------------|---------|------------------------------|----|----------|-------------|-----------|
| FRACTION | ±1/16 | DRAWN: | CH | DATE: | 11/19/2021 | APPROVED: |
| XX | ±0.01 | DESCRIPTION: | | | | |
| XXX | ±0.005 | CONCORD LEVEL AND STAIR RAIL | | | | |
| ANGLE | ±1.0° | SHEET 1 OF 8 | | REVISION | PART NUMBER | |
| FINISH | 125 RMS | SCALE 1:15 | | | N/A | |
| UNLESS OTHERWISE SPECIFIED | | WEIGHT: N/A | | | | |

CONCORD COMPONENT DETAILS

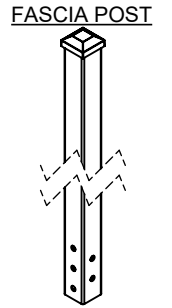
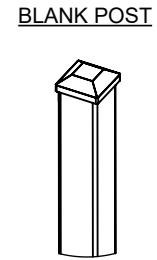
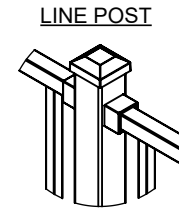
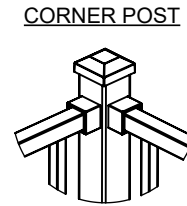
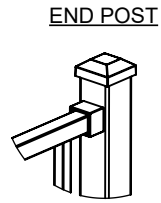
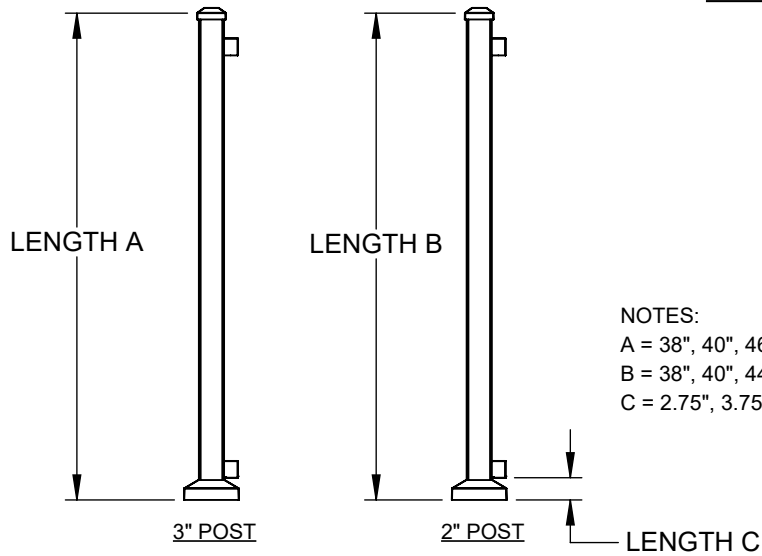

NOTES:
 A = 38", 40", 46"
 B = 38", 40", 44", 46", 48"
 C = 2.75", 3.75"

NOTE: BRACKET KITS INCLUDE (EXCEPT BLANK AND FASCIA POST), POST TOP, BRACKET COVERS, TRIM RING, VINYL SHIMS, HEX HEAD MOUNTING SCREWS, AND HEX BIT FOR ATTACHMENT TO STEEL OR WOOD POST.

FASCIA POST

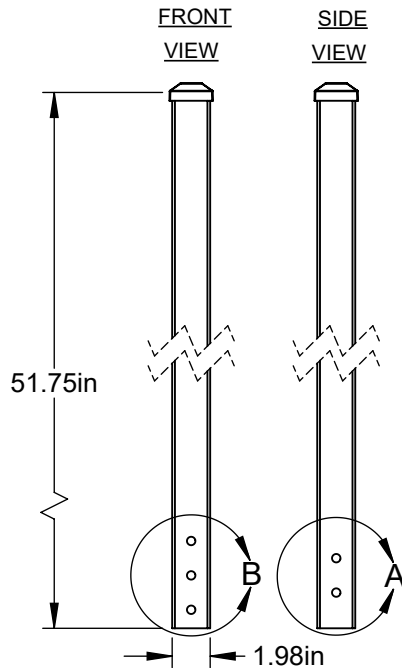

DETAIL B
SCALE 1 3.5

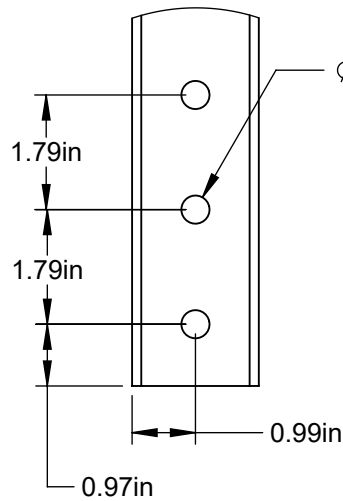

DETAIL A
SCALE 1 3.5

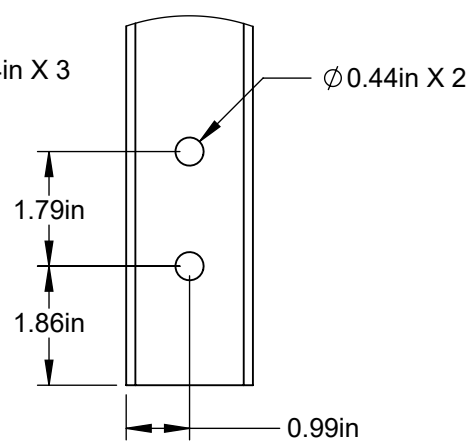

THE INFORMATION CONTAINED IN THIS DRAWING IS PROTECTED BY COPYRIGHT AND PATENT LAWS OF THE UNITED STATES AND OTHER COUNTRIES. ANY REPRODUCTION IN PART OR AS A WHOLE WITHOUT WRITTEN PERMISSION IS PROHIBITED.

| TOLERANCES | | | | | | | | |
|----------------------------|---------|--------------|----|----------|-------------|-----------|----------------------------------|--|
| FRACTION | ±1/16 | DRAWN: | CH | DATE: | 11/19/2021 | APPROVED: | | |
| XX | ±0.01 | DESCRIPTION: | | | | | CONCORD COMPONENT DETAILS | |
| XXX | ±0.005 | SHEET 2 OF 8 | | REVISION | PART NUMBER | | | |
| ANGLE | ±1.0° | SCALE 1:15 | | | N/A | | | |
| FINISH | 125 RMS | WEIGHT: N/A | | | | | | |
| UNLESS OTHERWISE SPECIFIED | | | | | | | | |

CONCORD COMPONENT DETAILS

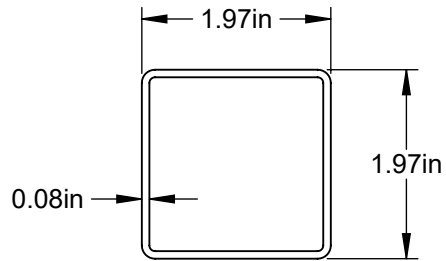

2" POST

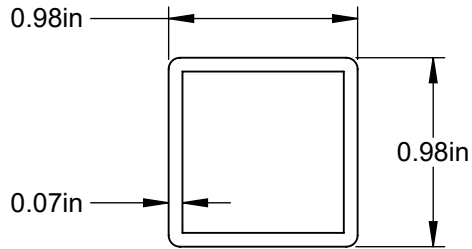

TOP / BTM RAIL

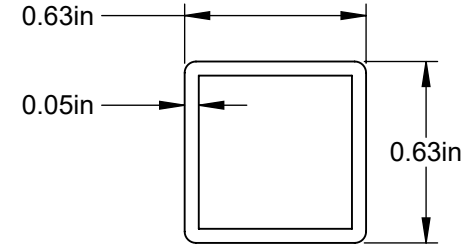

SQ BALUSTER

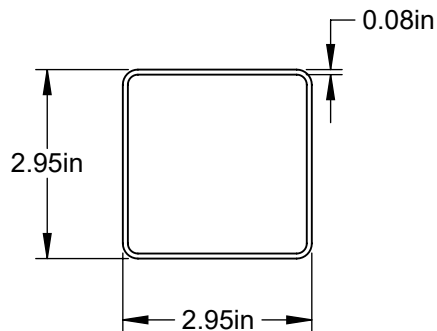

3" POST

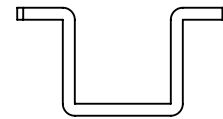

FLUSH MOUNT BRKT

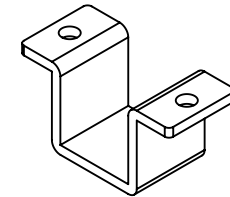

NOTE:
1. FLUSH BRKT USED TO ATTACH WOOD/DECK BOARD. FASTENERS ARE INCLUDED.

THE INFORMATION CONTAINED IN THIS DRAWING IS PROTECTED BY COPYRIGHT AND PATENT LAWS OF THE UNITED STATES AND OTHER COUNTRIES. ANY REPRODUCTION IN PART OR AS A WHOLE WITHOUT WRITTEN PERMISSION IS PROHIBITED.

| | | | | |
|----------------------------|---------|---|------------------|--------------|
| TOLERANCES | | | | |
| FRACTION | ±1/16 | DRAWN: TB | DATE: 11/19/2021 | APPROVED: CH |
| XX | ±0.01 | DESCRIPTION: CONCORD COMPONENT DETAILS | | |
| XXX | ±0.005 | SHEET 3 OF 8 | | |
| ANGLE | ±1.0° | SCALE 1:15 | | |
| FINISH | 125 RMS | WEIGHT: 43.66 | | |
| UNLESS OTHERWISE SPECIFIED | | REVISION PART NUMBER N/A | | |

CONCORD POST MOUNT CONNECTIONS

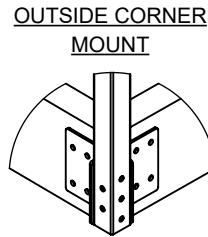
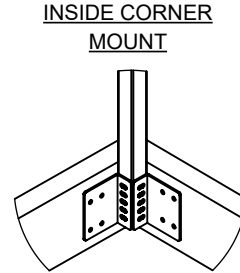
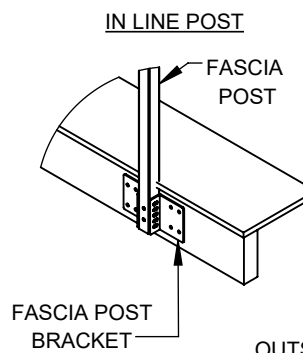
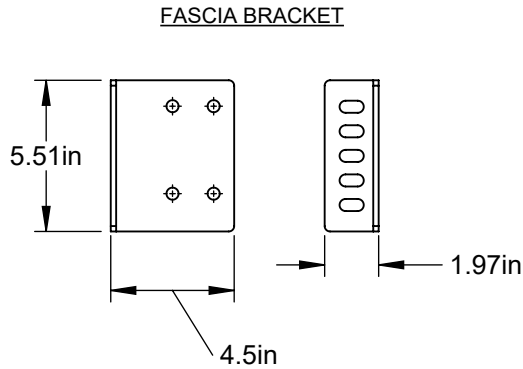

POST DETAILS WITH BOTTOM PLATE

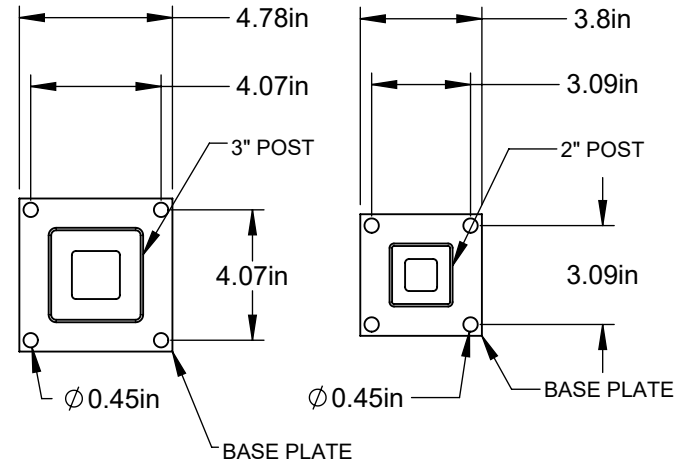

POST BASE CONNECTION INTO CONCRETE W/ WEDGE ANCHORS

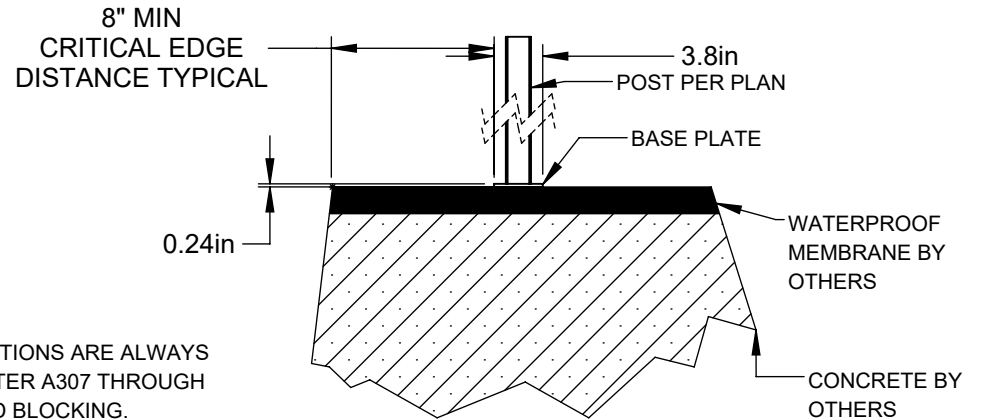

NOTE:
USE (4)-3/8"x7" LONG WEDGE ANCHORS USE SIMPSON SET EPOXY INTO CONCRETE WITH 5" EMBEDMENT DEPTH

POST BASE CONNECTIONS INTO WOOD WITH THRU BOLTS

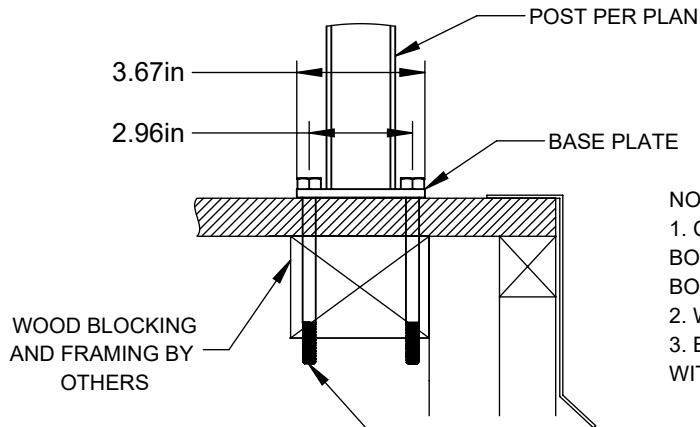

NOTE:
1. COMMERCIAL APPLICATIONS ARE ALWAYS BOLTED, USE 3/8" DIAMETER A307 THROUGH BOLTS INTO SOLID WOOD BLOCKING.
2. WOOD BLOCKING BY OTHERS.
3. BLOCKING MUST BE DESIGNED TO WITHSTAND PROPER LOADING.

USE 3/8" DIAMETER THROUGH BOLTS (MINIMUM LENGTH 5") INTO WOOD MEMBERS WITH MINIMUM EMBEDMENT DEPTH OF 4" INTO SOLID WOOD.

THE INFORMATION CONTAINED IN THIS DRAWING IS PROTECTED BY COPYRIGHT AND PATENT LAWS OF THE UNITED STATES AND OTHER COUNTRIES. ANY REPRODUCTION IN PART OR AS A WHOLE WITHOUT WRITTEN PERMISSION IS PROHIBITED.

| TOLERANCES | | | | | | | | |
|----------------------------|---------|--------------|----|----------|-------------|-----------|---------------------------------------|--|
| FRACTION | ±1/16 | DRAWN: | CH | DATE: | 11/19/2021 | APPROVED: | | |
| XX | ±0.01 | DESCRIPTION: | | | | | CONCORD POST MOUNT CONNECTIONS | |
| XXX | ±0.005 | SHEET 4 OF 8 | | REVISION | PART NUMBER | | | |
| ANGLE | ±1.0° | SCALE 1:15 | | | N/A | | | |
| FINISH | 125 RMS | WEIGHT: N/A | | | | | | |
| UNLESS OTHERWISE SPECIFIED | | | | | | | | |

CONCORD POST AND SURFACE MOUNT DETAIL

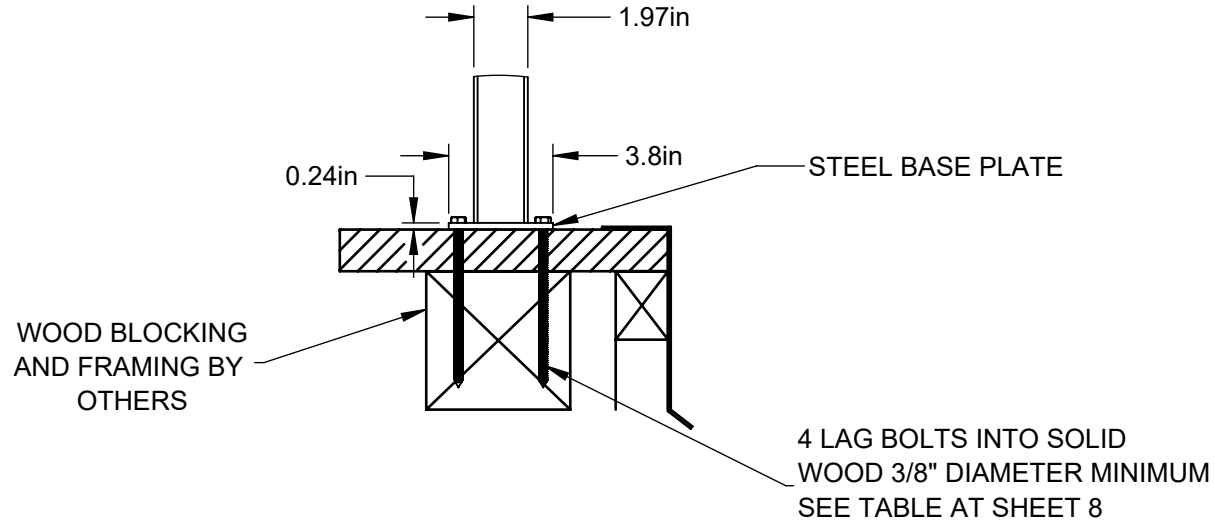

POST BASE CONNECTION INTO
WOOD WITH LAG BOLTS

NOTE:

1. WOOD BLOCKING BY OTHERS.
2. BLOCKING MUST BE DESIGNED TO WITHSTAND PROPER LOADING.

THE INFORMATION CONTAINED IN THIS DRAWING IS PROTECTED BY COPYRIGHT AND PATENT LAWS OF THE UNITED STATES AND OTHER COUNTRIES. ANY REPRODUCTION IN PART OR AS A WHOLE WITHOUT WRITTEN PERMISSION IS PROHIBITED.

| | | |
|--|------------------|-----------------------|
| Barrette OUTDOOR LIVING | | |
| DRAWN: CH | DATE: 11/19/2021 | APPROVED: |
| CONCORD POST AND SURFACE MOUNT DETAIL | | |
| SHEET 5 OF 8 | | REVISION PART NUMBER |
| SCALE 1:15 | | N/A |
| WEIGHT: N/A | | 0 |

CONCORD HORIZONTAL ROD RAIL LEVEL AND STAIR RAIL DETAILS

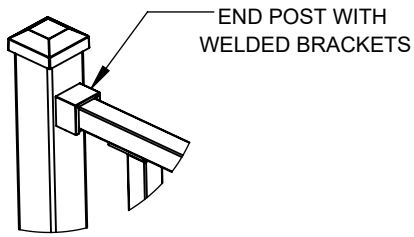

NOTES:
POST INCLUDES BRACKET
COVERS TO HIDE FASTENERS

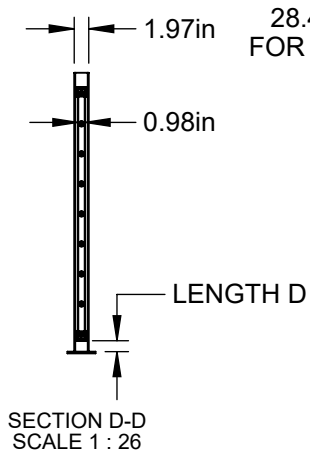

28.43in TYP.
FOR 96" MODEL

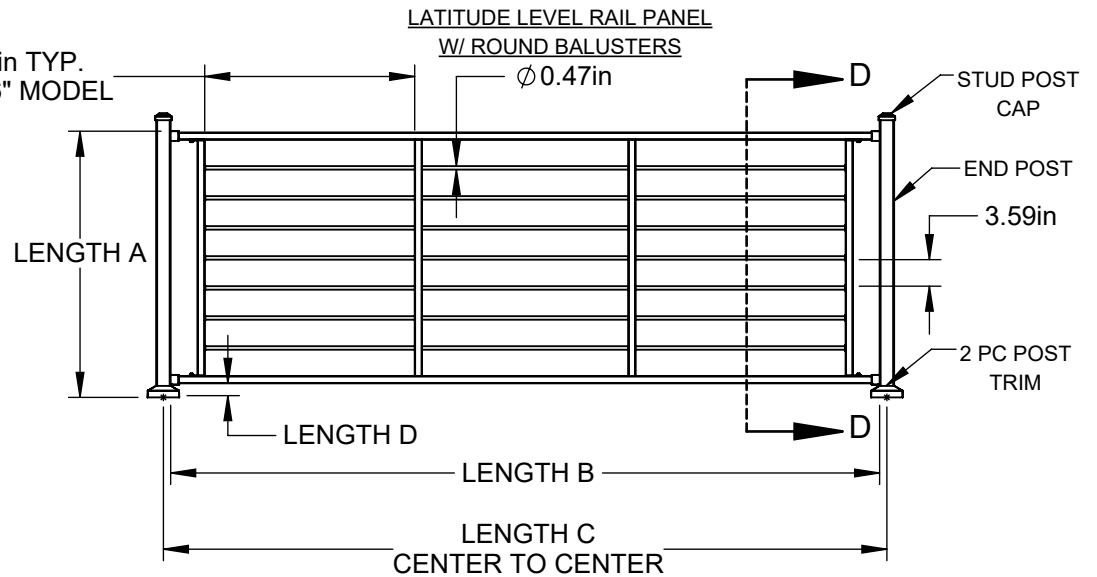

LATITUDE STAIR RAIL PANEL

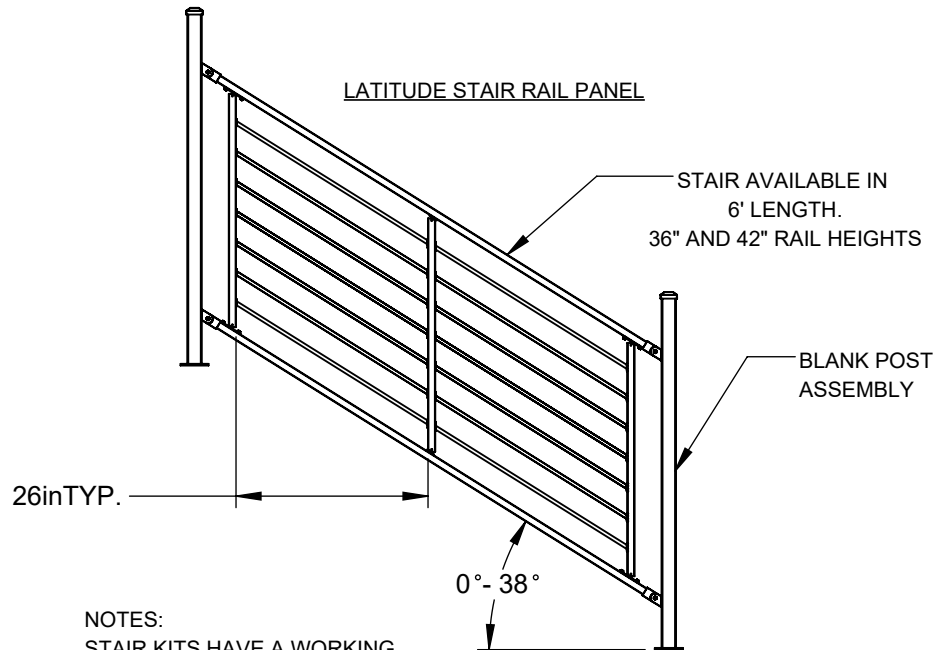

NOTES:
STAIR KITS HAVE A WORKING
RANGE OF 0-38 DEGREES.

NOTES:
(A) FINISHED RAIL HEIGHT = 36", 42"
(B) PANEL LENGTH = 71.75", 95.75"
(C) MAX SPAN = 96.00" X 42 IBC, 96.00" X 36 IRC
(D) BOTTOM SPACE = 1.75"
(E) 71.75" LENGTH HAS 1 MID SUPPORT.
95.75" LENGTH HAS 2 MID SUPPORTS.

THE INFORMATION CONTAINED IN
THIS DRAWING IS PROTECTED BY
COPYRIGHT AND PATENT LAWS
OF THE UNITED STATES AND
OTHER COUNTRIES. ANY
REPRODUCTION IN PART OR AS A
WHOLE WITHOUT WRITTEN
PERMISSION IS PROHIBITED.

| TOLERANCES | | | | | | | |
|----------------------------|---------|---|----|----------|-------------|-----------|--|
| FRACTION | ±1/16 | DRAWN: | CH | DATE: | 11/19/2021 | APPROVED: | |
| XX | ±0.01 | DESCRIPTION: | | | | | |
| XXX | ±0.005 | CONCORD HORIZONTAL ROD RAIL LEVEL AND STAIR RAIL DETAILS | | | | | |
| ANGLE | ±1.0° | SHEET 6 OF 8 | | REVISION | PART NUMBER | | |
| FINISH | 125 RMS | SCALE 1:15 | | | N/A | | |
| UNLESS OTHERWISE SPECIFIED | | WEIGHT: N/A | | | | | |

CONCORD HORIZONTAL ROD RAIL COMPONENT DETAILS

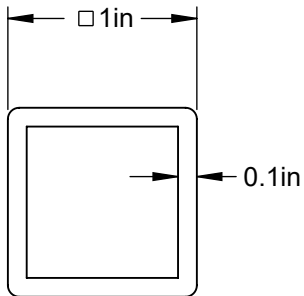

TOP AND BOTTOM
RAIL

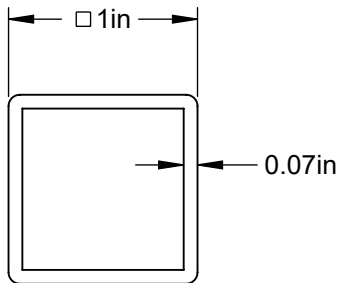

UPRIGHT

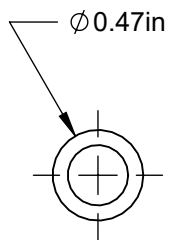

ROD INFILL

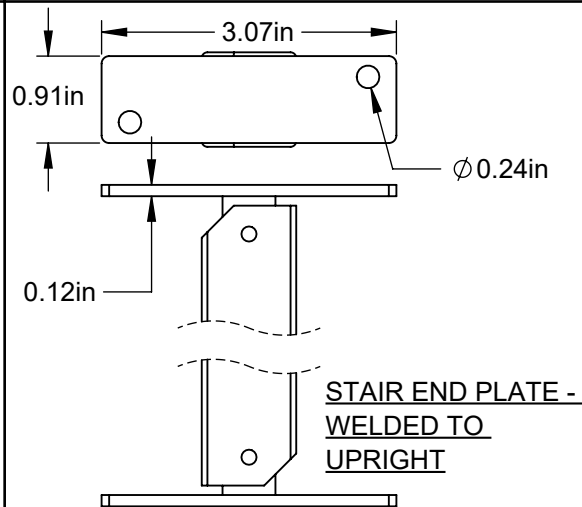

STAIR END PLATE -
WELDED TO
UPRIGHT

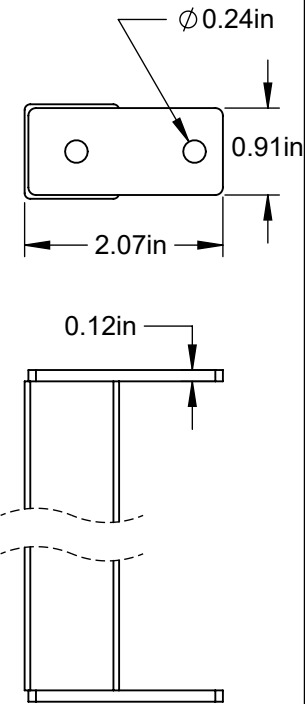

LEVEL END PLATE -
WELDED TO UPRIGHT

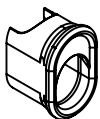
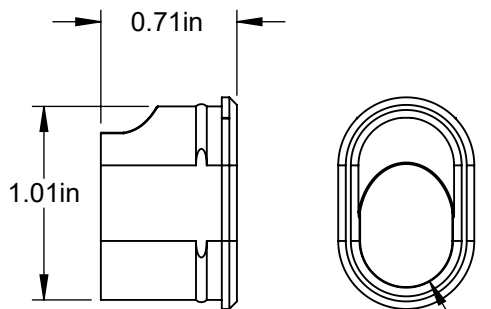

STAIR END BUSHING

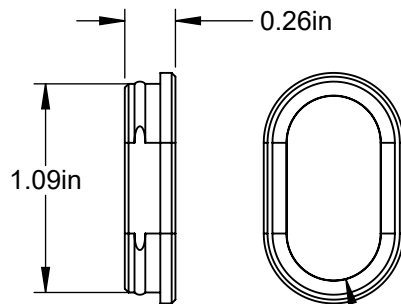

STAIR MID BUSHING

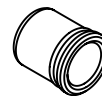
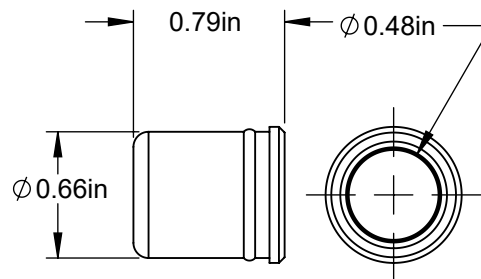

LEVEL BUSHING

THE INFORMATION CONTAINED IN THIS DRAWING IS PROTECTED BY COPYRIGHT AND PATENT LAWS OF THE UNITED STATES AND OTHER COUNTRIES. ANY REPRODUCTION IN PART OR AS A WHOLE WITHOUT WRITTEN PERMISSION IS PROHIBITED.

Barrette
OUTDOOR LIVING

| | | | |
|--|------------------|-------------|--|
| DRAWN: CH | DATE: 11/19/2021 | APPROVED: | |
| CONCORD HORIZONTAL ROD RAIL COMPONENT DETAILS | | | |
| SHEET 7 OF 8 | REVISION | PART NUMBER | |
| SCALE 1:1 | | N/A | |
| WEIGHT: N/A | | | |

MOUNTING SCHEDULE

| FOR RESIDENTIAL APPLICATIONS 36" HIGH | | | | | |
|---------------------------------------|--------|---|---|---|--|
| PANEL WIDTH | LOAD | RECOMMENDED BOLT APPLICATION | FOR LAG BOLT APPLICATION 3/8" DIA. SCREW. MINIMUM EMBEDDED SCREW THREAD LENGTH REQUIRED | FOR THROUGH BOLT APPLICATION | FOR CONCRETE ANCHOR APPLICATION 3/8" TITAN HD ANCHOR MINIMUM REQUIRED LENGTH (MINIMUM DISTANCE OF 4" FROM EDGE REQUIRED) |
| 8FT | 200LBS | LAG BOLT -OR- THROUGH BOLT -OR- CONCRETE ANCHOR | 3.5IN | 3/8" HEX BOLT 3/8" FLAT WASHER 3/8" LOCK WASHER 3/8" NUT | 4IN |
| 6FT | | | 3IN | | 3IN |
| 4FT | | | 2.5IN | | 3IN |

| FOR COMMERCIAL APPLICATIONS 42" HIGH | | | | | |
|--------------------------------------|--------|---|---|---|--|
| PANEL WIDTH | LOAD | RECOMMENDED BOLT APPLICATION | FOR LAG BOLT APPLICATION 3/8" DIA. SCREW. MINIMUM EMBEDDED SCREW THREAD LENGTH REQUIRED | FOR THROUGH BOLT APPLICATION | FOR CONCRETE ANCHOR APPLICATION 3/8" TITAN HD ANCHOR MINIMUM REQUIRED LENGTH (MINIMUM DISTANCE OF 4" FROM EDGE REQUIRED) |
| 8FT | 400LBS | THROUGH BOLT -OR- CONCRETE ANCHOR | 3.5IN | 3/8" HEX BOLT 3/8" FLAT WASHER 3/8" LOCK WASHER 3/8" NUT | 4IN |
| 6FT | 300LBS | LAG BOLT -OR- THROUGH BOLT -OR- CONCRETE ANCHOR | 3IN | | 3IN |
| 4FT | 200LBS | LAG BOLT -OR- THROUGH BOLT -OR- CONCRETE ANCHOR | 2.5IN | | 3IN |



| | | | | |
|--------------------------|----|----------|-------------|-----------|
| DRAWN: | CH | DATE: | 11/19/2021 | APPROVED: |
| DESCRIPTION: | | | | |
| MOUNTING SCHEDULE | | | | |
| SHEET 8 OF 8 | | REVISION | PART NUMBER | |
| SCALE 1:15 | | 0 | N/A | |
| WEIGHT: N/A | | | | |

THE INFORMATION CONTAINED IN THIS DRAWING IS PROTECTED BY COPYRIGHT AND PATENT LAWS OF THE UNITED STATES AND OTHER COUNTRIES. ANY REPRODUCTION IN PART OR AS A WHOLE WITHOUT WRITTEN PERMISSION IS PROHIBITED.