

BELLA PREMIER LEVEL AND STAIR RAIL DETAILS

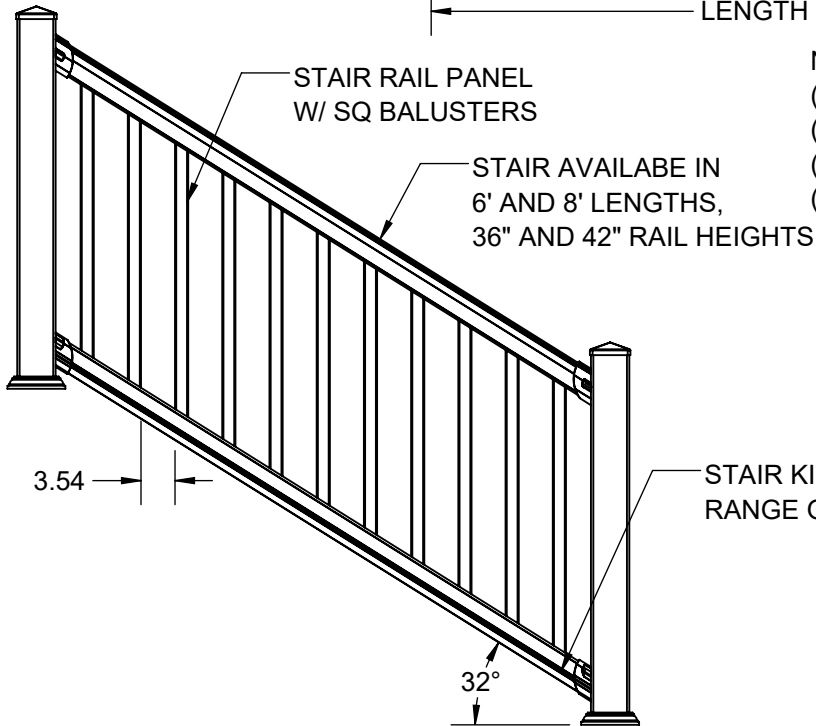
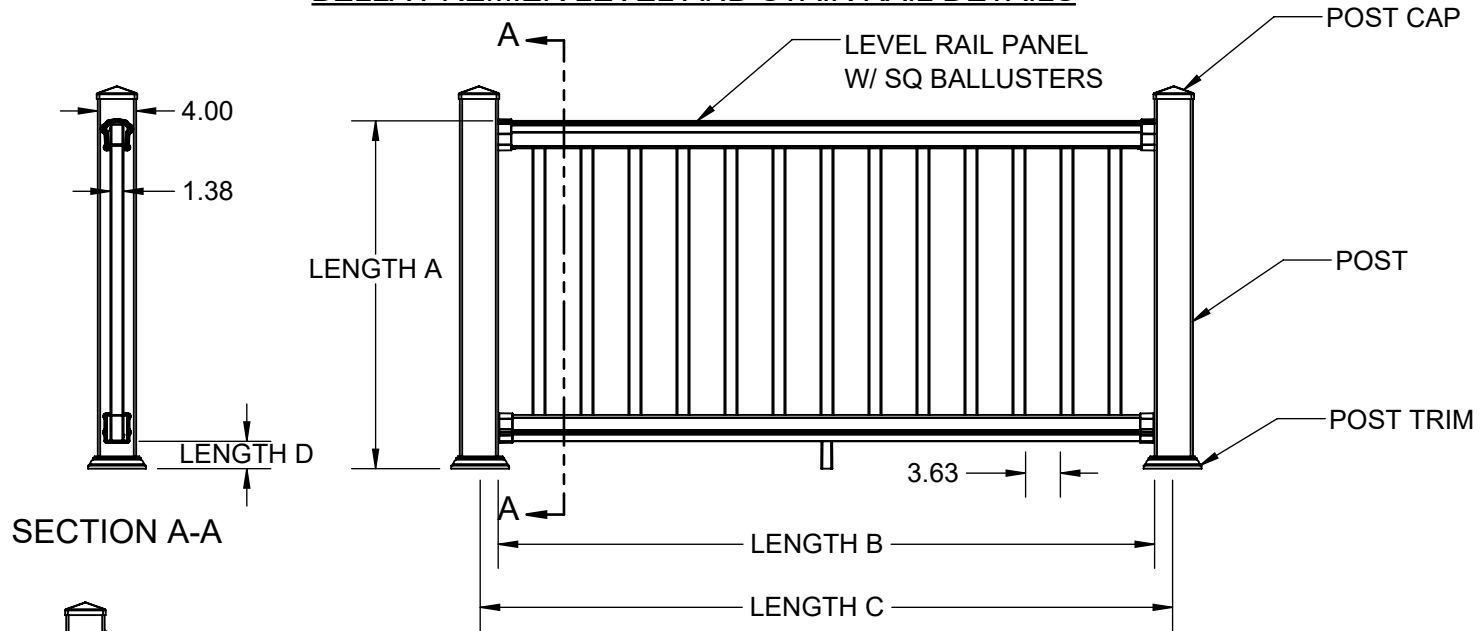

NOTE:

- (A) FINISHED RAIL HEIGHT = 36", 42" (SQ BALLUSTERS ONLY)
- (B) PANEL LENGTH = 67.125", 91.125", 115.125"
- (C) MAX SPANS = 115" (36" HIGH, IRC), 91" (42" HIGH, IBC)
- (D) BOTTOM SPACE = 3"

STAIR KITS HAVE A WORKING RANGE OF 26-38 DEGREES

THE INFORMATION CONTAINED IN THIS DRAWING IS PROTECTED BY COPYRIGHT AND PATENT LAWS OF THE UNITED STATES AND OTHER COUNTRIES. ANY REPRODUCTION IN PART OR AS A WHOLE WITHOUT WRITTEN PERMISSION IS PROHIBITED.

Barrette OUTDOOR LIVING		
DRAWN: CH	DATE: 11/15/2021	APPROVED:
DESCRIPTION: BELLA PREMIER LEVEL AND STAIR RAIL		
SHEET 1 OF 3	REVISION	PART NUMBER
SCALE 1:20	0	N/A
WEIGHT: N/A		

TOP AND BOTTOM RAIL

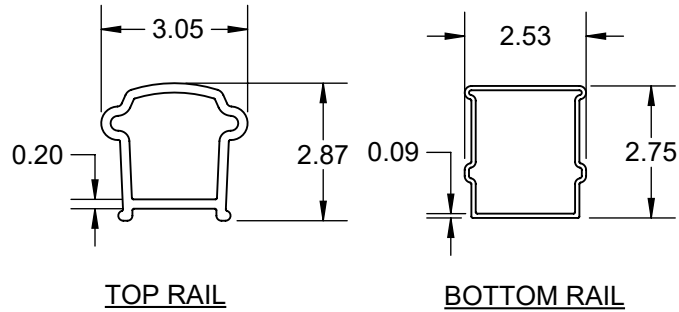

STIFFENER

NOTE: STIFFENER ONLY
PRESENT IN 8' AND 10' PANELS.
SEE PFS TECO RESEARCH
REPORT 0101.

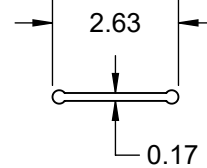

ACCESSORIES

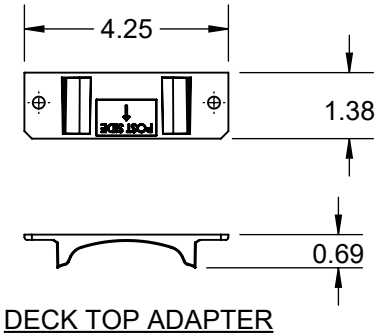

POST COMPONENTS

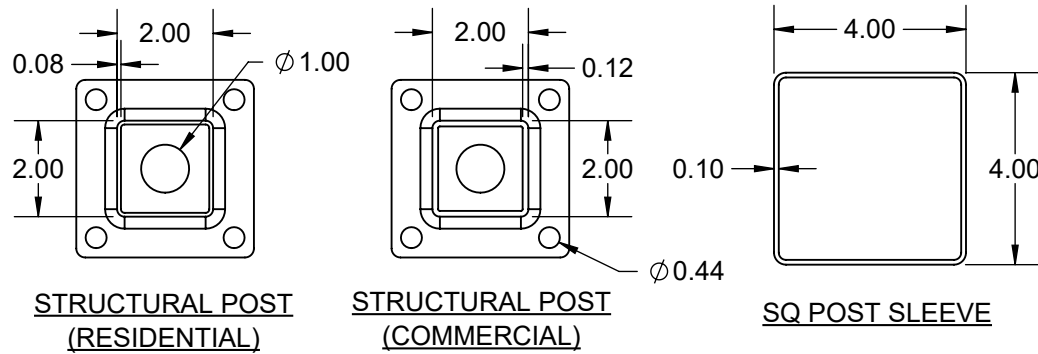

BALUSTERS

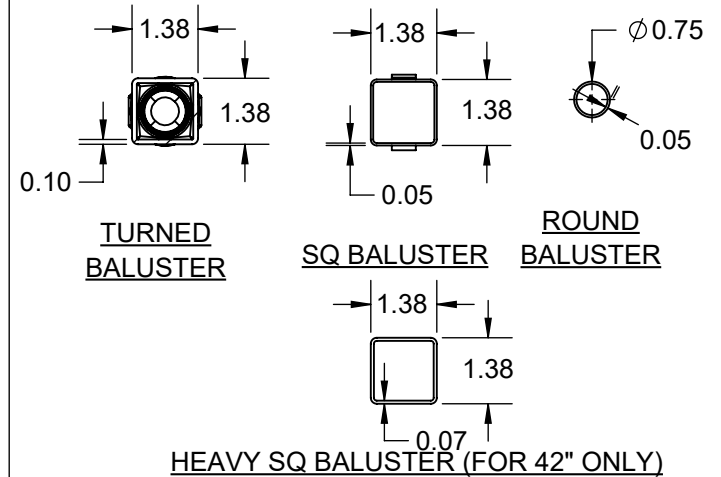

THE INFORMATION CONTAINED IN THIS DRAWING IS PROTECTED BY COPYRIGHT AND PATENT LAWS OF THE UNITED STATES AND OTHER COUNTRIES. ANY REPRODUCTION IN PART OR AS A WHOLE WITHOUT WRITTEN PERMISSION IS PROHIBITED.

Barrette OUTDOOR LIVING		
DRAWN: CH	DATE: 11/15/2021	APPROVED:
DESCRIPTION: BELLA PREMIER PROFILE DETAILS		
SHEET 2 OF 3	REVISION	PART NUMBER
SCALE 1:4		N/A
WEIGHT: N/A		

BELLA PREMIER POST AND MOUNT DETAILS

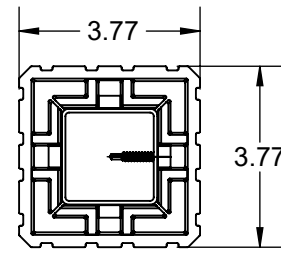
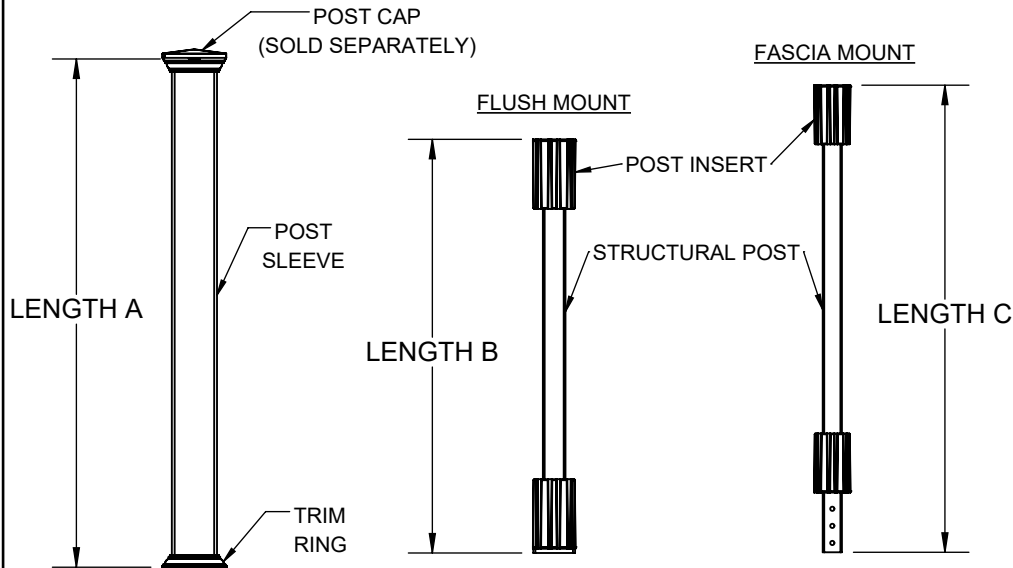

POST INSERT
TOP VIEW

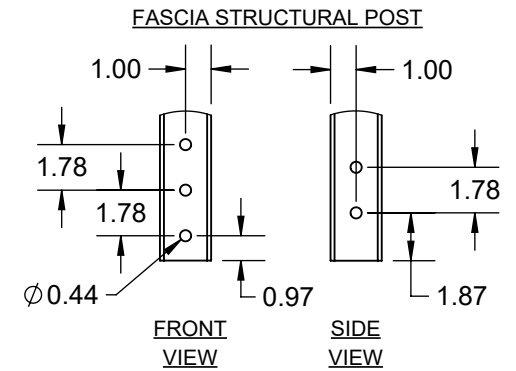

POST BASE CONNECTION INTO
CONCRETE W/ WEDGE ANCHORS

NOTE:
 (A) = 39", 45", 54", 100", 108", 120"
 (B) = 36.625", 42.625"
 (C) = 42.625", 48.625"

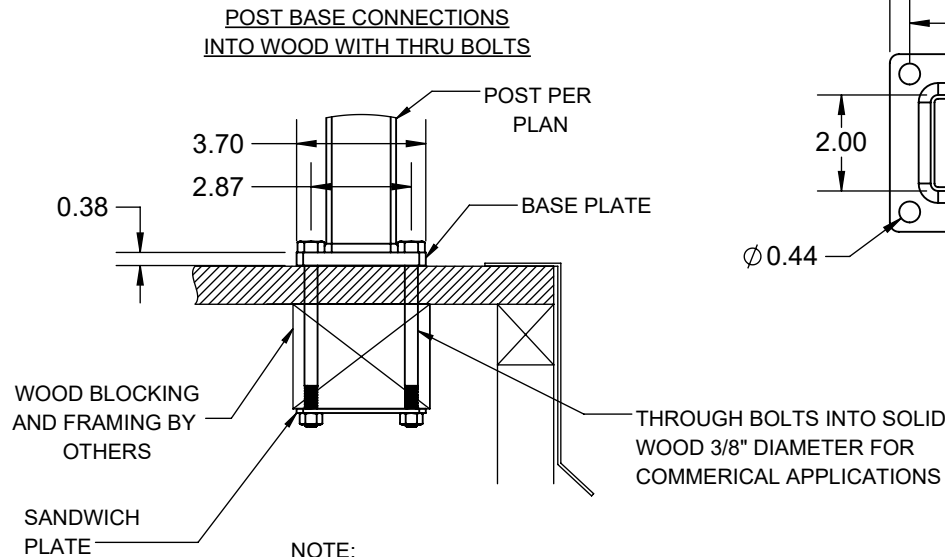

NOTE:
 1. COMMERCIAL APPLICATIONS ARE ALWAYS BOLTED, USE 3/8" DIAMETER A307 THROUGH BOLTS (MIN 5" LENGTH) INTO SOLID WOOD BLOCKING (MIN 4" EMBEDMENT DEPTH).
 2. WOOD BLOCKING BY OTHERS.
 3. BLOCKING MUST BE DESIGNED TO WITHSTAND PROPER LOADING.

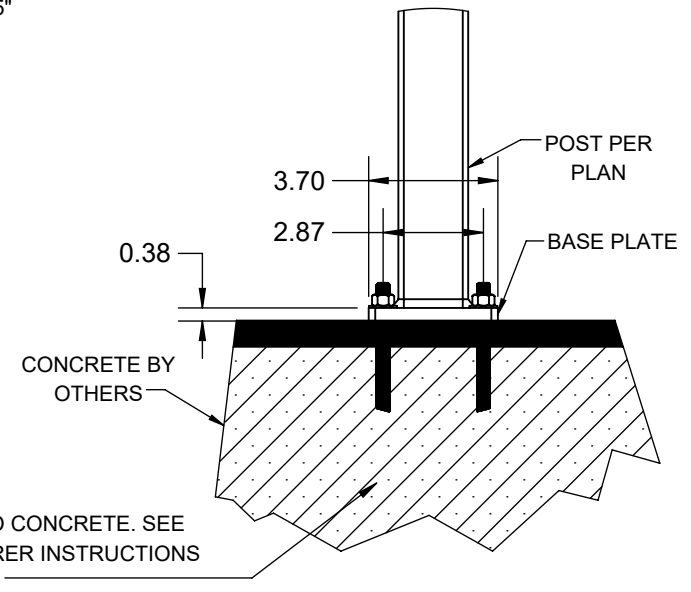
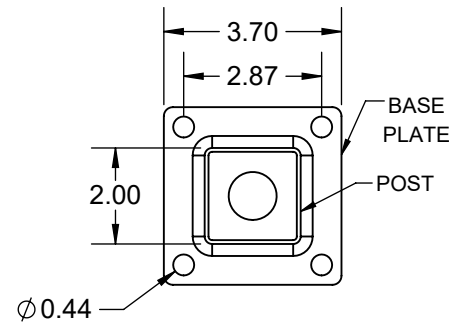

ANCHOR INTO CONCRETE. SEE MANUFACTURER INSTRUCTIONS FOR DETAILS.

THE INFORMATION CONTAINED IN THIS DRAWING IS PROTECTED BY COPYRIGHT AND PATENT LAWS OF THE UNITED STATES AND OTHER COUNTRIES. ANY REPRODUCTION IN PART OR AS A WHOLE WITHOUT WRITTEN PERMISSION IS PROHIBITED.

TOLERANCES						
FRACTION	±1/16	DRAWN:	CH	DATE:	6/7/2021	APPROVED:
XX	±0.01	BELLA PREMIER POST & MOUNT DETAILS				
XXX	±0.005					
ANGLE	±1.0°	SHEET 3 OF 3		REVISION	PART NUMBER	
FINISH	125 RMS	SCALE 1:15		N/A		
UNLESS OTHERWISE SPECIFIED		WEIGHT: N/A				