



# Building Product Evaluation Report 0101

## Select, Premier, and Barrette PVC Guardrail Systems Barrette Outdoor Living

Initial Acceptance: October 7, 2017

Expiration: October 6, 2023

Revision: October 18, 2021

### TYPE OF ACCEPTANCE

#### **Product Material – Wood and Plastics**

CSI Specification Division: 06 50 00 (Structural Plastic) and 06 63 00 (Plastic Railing)

### MANUFACTURER IDENTIFICATION:

#### **Barrette Outdoor Living**

740 North Main Street

Bulls Gap, TN 37711

1-800-336-2383

[www.barretteoutdoorliving.com](http://www.barretteoutdoorliving.com)

### EVALUTATION REPORT SUBJECT:

Guardrail Systems for Exterior Applications

Installation on construction complying with the International Residential Code® (IRC) or with the International Building Code® (IBC), including IBC exceptions in Section 1015.3 of the IBC.

### DESCRIPTION OF BUILDING COMPONENTS:

Barrette Outdoor Living guardrail systems come with three identification names: **Select, Premier, and Barrette PVC Composite** (also marketed as **Merrimack** and **Prescott**). These guardrail Systems are for use in areas as referenced in the Applicable Codes, and provide a protective barrier for walking areas, balconies, porches, stairs and ramps. These guardrail systems are manufactured by an extrusion process and are produced in white and other colors.

#### **1. Guardrail – Select**

- (a) The **Select** guardrail system consists of a top rail, bottom rail, balusters, and aluminum reinforcing inserts. The components top, bottom, and balusters are manufactured with PVC material by the co-extruded process, except for the inserts.
- (b) The **Select** guardrail system has a top rail that is rectangular in shape, hollow in the center, has rounded edges, is pre-routed for balusters, and has a PVC cap stock on the top rail. The top rail requires one of the “U” shaped 6005-T5/6061-T5 aluminum insert reinforcements, indicated in Table 2 in this Report. The top rail is connected to the supports utilizing a PVC bracket. See Table1 in this Report for drawings and dimensions.
- (c) The **Select** guardrail system has a bottom rail that is rectangular in shape, hollow in the center, has rounded edges, and is pre-routed for balusters. The bottom rail has “U” shape 6005-T5/6061-T5 aluminum insert reinforcement which must be used with the 10-foot guardrail system. The bottom rail connects to the supports utilizing a molded PVC bracket. See Table1 in this Report for drawings and dimensions.
- (d) The **Select** guardrail system has one baluster design. The baluster is square in shape, has rounded edges, and is hollow in the center. See Table 1 in this Report for baluster drawing and dimensions.



- (e) The **Select** guardrail system connections for the top and bottom rail to the supports are brackets. The brackets are secured to the posts with steel screws (stainless, corrosion plated, or galvanized) suitable for use in preservative-treated wood. See Tables 1 and 3 of this Report for a drawing of the bracket and the number of fasteners required.
- (f) See Table 2 in this Report for the **Select** guardrail system heights and lengths. The guardrail system that is 6 feet in length requires intermediate support between the supports under the bottom rail, and the guardrail systems that are 8 feet and 10 feet in length require two supports that are located under the bottom rail and are evenly spaced between the supports. See manufacturer's installation instructions BOM 34107846 dated 2-14-17.

**2. Guardrail – Premier and Barrette PVC Composite (also marketed as Merrimack and Prescott).**

- (a) The **Premier** and **Barrette PVC Composite** guardrail systems consist of a top rail, bottom rail, balusters, and aluminum reinforcing insert. The bottom and baluster components (except for the round baluster) are manufactured by the co-extruded process with PVC material. The top rail is manufactured by the co-extruded process with CompositCore™ material.
- (b) The **Premier** and **Barrette PVC Composite** guardrail systems have a top rail that has a contoured profile (CompositCore) shape, is hollow in the center, has rounded edges, is pre-routed for balusters, and has a PVC cap stock on the top rail. The top rail has a "dog bone" 6005-T5 aluminum insert that must be used with the 8 foot and 10-foot guardrail systems. The top rail is connected to the supports utilizing a PVC bracket. See Table 1 in this Report for drawings and dimensions.
- (c) The **Premier** and **Barrette PVC Composite** guardrail systems have a bottom rail that is rectangular in shape, is hollow in the center, has rounded edges, and is pre-routed for balusters. The bottom rail connects to the supports utilizing a molded PVC bracket. See Table 1 in this Report for drawings and dimensions.
- (d) The **Premier** and **Barrette PVC Composite** guardrail systems have three baluster designs. Two balusters (Yorktown and Square) are square in shape, have rounded edges, and are hollow in the center. The third baluster (aluminum 6005-T5) is circular in shape and is hollow in the center. The Yorktown, Circular, and Square balusters are only used in the **Premier**, and the Square and Circular balusters are only used in the **Barrette PVC Composite**. See Tables 1 in this Report for baluster drawings and dimensions.
- (e) The **Premier** and **Barrette PVC Composite** guardrail systems connections for the top and bottom rail to the supports are brackets. The brackets are secured to the posts with steel screws (stainless, corrosion plated or galvanized) suitable for use in preservative-treated wood. See Tables 1 and 3 in this Report for drawing of the bracket and number of fasteners required.
- (f) See Table 2 in this Report for the **Premier** and **Barrette PVC Composite** guardrail systems height and length. The guardrail system that is 6 feet in length requires intermediate support between the supports under the bottom rail, and the guardrail systems that are 8 feet and 10 feet in length require two supports that are located under the bottom rail and are evenly spaced between the supports. See manufacturer's installation instructions BOM 34107347 dated 4-27-15.

**3. Stairs – Select, Premier, and Barrette PVC Composite**

- (a) Both guardrail systems can be used as stair guards. See Tables 1, 2, and 3 in this Report for the maximum length between posts, bottom rail supports, top and bottom rail connection brackets, and fasteners required.
- (b) When guardrails are used with stairs, the guardrail must be installed in accordance with the manufacturer's installation instructions and information located in Tables 1, 2, and 3 in this Report. When the manufacturer's installation instructions differ from this Report, this Report governs. Additionally, in order to comply with the IBC or IRC graspability requirements, a separate handrail complying with IBC Section 1014.3 or IRC Section R311.7.8.3 must be provided. Specific details regarding the construction, installation, and attachment to the stair guardrail and/or posts have not been evaluated and are outside the scope of this Report. Specific details when required must be furnished to the authority having jurisdiction.

**APPLICABLE CODES:**

- 2015, 2018, and 2021 International Building Code (IBC)
- 2015, 2018, and 2021 International Residential Code (IRC)



**APPLICABLE CHARACTERISTICS REVIEWED:**

**1. Structural Performance:**

- (a) Barrette Outdoor Living **Select**, **Premier**, and **Barrette PVC Composite** guardrail systems have been reviewed for maximum span as indicated in Table 2. Table 2 in this Report also indicates the limitations of use evaluated for each design.

**2. Durability - Temperature:**

- (a) Barrette Outdoor Living **Select** and **Premier/Barrette PVC Composite** guardrail systems have been reviewed and evaluated for a temperature range of -20 degrees F (-29 degrees C) to 125 degrees F (52 degrees C).

**3. Flame Spread Index:**

- (a) Barrette Outdoor Living **Select**, **Premier**, and **Barrette PVC Composite** guardrail systems flame spread ratings were less than 200 for CompositCore™ and PVC material when tested in accordance with ASTM E84, *Standard Test Method for Surface Burning Characteristics of Building Materials*.

**4. Decay Resistance:**

- (a) The material used in the Barrette Outdoor Living **Select**, **Premier**, and **Barrette PVC Composite** guardrail systems in this Report does not contain any wood and has been deemed comparable to naturally resistant wood or to preservative-treated wood for resistance to fungal decay.

**5. Termite Resistance:**

- (a) The material used in the Barrette Outdoor Living **Select**, **Premier**, and **Barrette PVC Composite** guardrail systems in this Report does not contain any wood and has been deemed equivalent to naturally resistant wood or to preservative-treated wood for resistance to termite attack.

**6. UV Testing:**

- (a) The UV testing was conducted, and an appropriate adjustment factor was applied in accordance with ASTM D7032, *Standard Specification for Establishing Performance Ratings for Wood-Plastic Composite Deck Boards and Guardrail Systems (Guards or Handrails)*.

**7. Fastening:**

- (a) Barrette Outdoor Living **Select**, **Premier**, and **Barrette PVC Composite** guardrail systems top and bottom rails are fastened to posts with brackets using steel (stainless, corrosion plated or galvanized) screws. See Table 3 in this Report and the manufacturer's installation instructions.
- (b) Barrette Outdoor Living guardrail systems connection for the stairs are as follows: The **Select** guardrail systems are connected with a molded two-piece adjustable top and bottom brackets. The socket bracket receives the end of the rail (top or bottom) and is mounted to a stationary base. The base is adjustable up and down to meet the slope of the stairs. The **Premier** and **Barrette PVC Composite** guardrail systems are connected with molded single piece sockets that allow the rail to pivot to the required angle or to be cut as required. See Table 1 of this Report for drawings of the brackets.
- (c) The fasteners and brackets are supplied by the manufacturer and must be used in the installation of the Barrette Outdoor Living guardrail system. Use of other brackets and fasteners is not covered under this Report.

**8. Posts:**

- (a) Wood posts or other wood support framing members are not covered under this Report and fall outside of this Report. Wood posts and other wood must meet the load requirement in the building code and the wood members must have a minimum specific gravity of 0.50 (Southern Pine or better) and minimum thickness to allow full penetration of bracket mounting screws. Other wood posts or wood members not meeting these requirements are not covered under this Report.

**APPLICABLE USES:**

The Barrette Outdoor Living guardrail systems evaluated in this Report are for installations on construction complying with IRC or IBC including Exceptions indicated in section 1015.3. See Table 2 for guardrail system limitations.



**LIMITATIONS OF ACCEPTANCE:**

The Barrette Outdoor Living **Select**, **Premier**, and **Barrette PVC Composite** guardrail systems described in this Report comply with those codes listed in the Applicable Codes section above and are subject to the following conditions:

1. Barrette Outdoor Living **Select**, **Premier**, and **Barrette PVC Composite** guardrail systems are limited to exterior construction complying with the IRC and the IBC. The guardrail systems provide a protective barrier for walking areas, balconies, porches, and ramps. See Table 2 for additional restrictions and limitations.
2. Installation of the guardrail systems must comply with this Report; the applicable manufacturer's published installation instructions identified as BOM 34106886 for **Select** dated 7-23-15, and identified as BOM 34107347 for **Premier** and **Barrette PVC Composite** dated 4-27-15; and the applicable code. When the guardrail installation instructions differ from this Report, this Report governs.
3. The fasteners described in this Report have been evaluated for the installation of the Barrette Outdoor Living **Select** and **Premier**, and **Barrette PVC Composite** guardrails attachment to wood posts. Structural wood posts and framing support members for posts must be designed to satisfy load requirements (live and dead) indicated in the building code. Material necessary for anchorage of the guardrail system(s) and compatibility of the fasteners to the treated supporting construction has not been evaluated.
4. The Barrette Outdoor Living **Select**, **Premier**, and **Barrette PVC Composite** guardrail systems indicated in the report must be fastened to the supporting construction (wood posts) as indicated in the manufacturer's installation manual and as outlined in this Report. When guardrail fastening instructions differ from this Report, this Report governs.
5. The top rail component for the Barrette Outdoor Living **Select**, **Premier**, and **Barrette PVC Composite** guardrail systems do not meet the graspability requirements when used as a handrail for stairs. See Description of Building Components 3(b) in this Report for additional requirements.
6. When required, the guardrail system, including a stair handrail (see Description of Building Components 3(b)), must be designed by a design professional and submitted to the authority having jurisdiction for final acceptance.
7. Barrette Outdoor Living **Select**, **Premier**, and **Barrette PVC Composite** guardrails have not been evaluated as a member of a fire-resistance-rated assembly.
8. Barrette Outdoor Living has a Third-Party inspection program provided by PFS Corporation (AA-652).
9. The structural design for code compliance of supporting members for the guardrail, have not been evaluated and is not part of this Report.

**DOCUMENTATION SUBMITTED:**

Submitted data was provided in accordance with PFS TECO 1601 (Quality control manual, Specifications, Manufacturer's installation instructions, Test data and Description information) and the products have been evaluated in accordance with ICC-ES AC174, *Acceptance Criteria for Deck Board Span Ratings and Guardrail Systems (Guards and Handrails)*.

This Report was formerly published as PFS TECO Research Report 0101 (RR 0101).

**PRODUCT IDENTIFICATION:**



The Barrette Outdoor Living guardrail assembly systems must be identified with a label on each component or the packaging. The required information is as follows: Barrette Outdoor Living, product identification (**Select**, **Premier**, or **Barrette PVC Composite**), compliance to ASTM D7032 including the maximum guardrail span, the PFS TECO Building Product Evaluation Report number (BPER 0101), and the PFS Certification Mark (see image below). Guardrails that are 36 inches high require a label indicating the following: "Guardrail installation in residential (1 & 2 Family) units only." Guardrails without this information are not covered under this Report



**Table 1: Schematics of Select, Premier, and Barrette PVC Composite Guardrail System Components**

Description	Select	Premier	Barrette PVC Composite (aka Merrimac, Prescott)
Top Rail			
Top Rail Insert		<p style="text-align: center;">Dog Bone</p>	
Bottom Rail			
Bottom Rail Insert	<p style="text-align: center;">1/16" U</p>	None	
Bottom Rail Support Block			

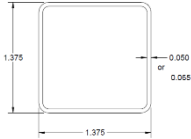
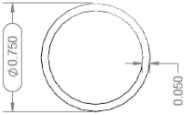
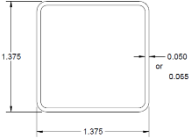
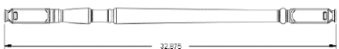
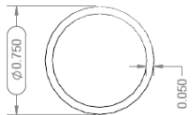
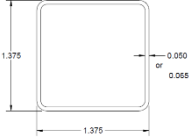
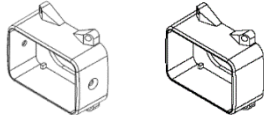
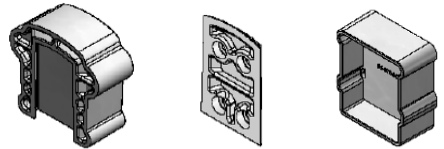
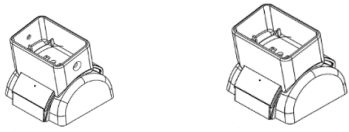
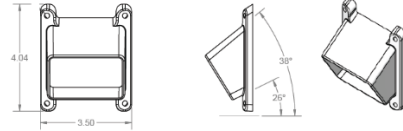

Description	Select	Premier	Barrette PVC Composite (aka Merrimac, Prescott)
Baluster	 <p>1-3/8" Square PVC</p>	 <p>3/4" Aluminum</p>  <p>1-3/8" Square PVC</p>  <p>Yorktown</p>	 <p>3/4" Aluminum</p>  <p>1-3/8" Square PVC</p>
Bracket - Level	 <p>Top Bracket    Bottom Bracket</p>	 <p>Top Bracket    Bracket Base    Bottom Bracket</p>	
Bracket - Stair	 <p>Angle Wizard Top Bracket    Angle Wizard Bottom Bracket</p>  <p>Single Molded Socket</p>	 <p>Top Rail Upper Socket    Bottom Rail Upper Socket</p>	 <p>Top Rail Lower Socket    Bottom Rail Lower Socket</p>



**Table 2: Maximum Span Table for Select, Premier, and Barrette PVC Composite Guardrail Assembly  
(For IRC Residential and IBC One- and Two-Family Residential Dwellings – (TYPE V-B))**

Railing Type	Railing Assembly for Compliance with IBC Maximum Rail Height 42 inches					Railing Assembly for Compliance with IRC Maximum Rail Height 36 inches				
	Top Rail Insert	Bottom Rail Insert	Baluster Type	Baluster Length	Maximum Span (in)	Top Rail Insert	Bottom Rail Insert	Baluster Type	Baluster Length	Maximum Span (in)
<b>Select Guardrail System Assembly</b>										
Level	1/16 inch U	None	1-3/8" Square Baluster 0.065" Thick	38-7/8"	67-1/2	1/16 inch U	None	1-3/8" Square Baluster 0.055" Thick	32-7/8"	67-1/2
Level	1/8 inch U	None			91-1/2	1/8 inch U	1/16 inch U			115-3/8
Stair with Angle Wizard Brackets	1/8 inch U	None			71-1/2	1/8 inch U	None			96
Stair with Molded PVC Brackets	1/8 inch U	None			91-1/2	1/8 inch U	None			91-1/2
Stair with Molded PVC Brackets	1/16 inch U	None			67-1/2	1/16 inch U	None			67-1/2
<b>Premier Guardrail System Assembly</b>										
Level	None	None	1-3/8" Square Baluster 0.065" Thick	38-7/8"	67	None	None	1-3/8" Square 0.055" Thick, ¾" Al Tube, 1-3/8" Yorktown	32-7/8"	67
Level	Dog Bone	None			91	Dog Bone	None			115
Stair	Dog Bone	None			90	Dog Bone	None			90
<b>Barrette PVC Composite (aka Merrimac, Prescott) Guardrail System Assembly</b>										
Level	None	None	1-3/8" Square Baluster 0.065" Thick	39-7/8"	67	None	None	1-3/8" Square 0.055" Thick	33-7/8"	67
Level	Dog Bone	None			91	Dog Bone	None			115
Stair	Dog Bone	None			90	Dog Bone	None			90

for SI conversion: 1 in = 25.4 mm, 1 psi = 6.895 kPa, 1 lbf = 0.0044 kN

Refer to Table 3 for fastening schedule

Maximum span is clear length between posts measured parallel to top/bottom rail



**Table 3: Fastening Schedule for Select, Premier, and Barrette PVC Composite Guardrail Assembly**

Location	Connection	Fasteners
<b>Select Guardrail Assembly</b>		
Level – Top Rail	Rail Bracket to Post <sup>4</sup>	Four #10 x 1-1/4" Pan #2 Square Drive 302 SS screw <sup>1</sup>
	Rail Bracket to Rail	Two #10 x 1" Flat Head Square Drive 302 SS screw
Level – Bottom Rail	Rail Bracket to Post	Four #10 x 1-1/4" Pan #2 Square Drive, 302 SS screw <sup>1</sup>
	Rail Bracket to Rail	Slip Fit – No mechanical connection
Top Rail Stair with Angle Wizard Bracket	Rail Bracket to Post	Four #10 x 2" Pan #2 Square Drive SDS 410 SS screw <sup>2</sup>
	Rail Bracket to Rail	Two #10 x 1" Flat Head SS screw
	Rail Bracket to Bracket Base	Two #10x 1" Pan 18-8 SS screw
Bottom Rail Stair with Angle Wizard Bracket	Rail Bracket to Post	Four #10 x 1-1/2" Pan #2 Square Drive SDS 410 SS screw <sup>2</sup>
	Rail Bracket to Rail	Slip fit – No mechanical connection
	Rail Bracket to Bracket Base	One #10 x Pan 18-8 SS screw
Top Rail Stair with Molded PVC Bracket	Rail Bracket to Post	Four #10 x 1-1/4" Pan #2 Square Drive 410 SS self-drilling screw
	Rail Bracket to Rail	One #10 x 1" Pan #2 Square Drive 410 SS self-drilling screw
Bottom Rail Stair with Molded PVC Bracket	Rail Bracket to Post	Four #10 x 1-1/4" Pan #2 Square Drive 410 SS self-drilling screw
	Rail Bracket to Rail	Slip fit – No mechanical connection
Support Block <sup>3</sup> to Bottom Rail		One #10 x 3/4" Pan #2 Square Drive Tapping 302 SS screw
<b>Premier and Barrette PVC Composite Guardrail Assembly</b>		
Level – Top Rail Bracket Base	Base to Post	Four #10 x 2" Pan #2 Square Drive SDS 410 SS screw <sup>1</sup>
	Rail Bracket to Base	Slip fit – No mechanical connection
Level – Top Rail (Rail Bracket)	Rail Bracket to Post	Two #10 x 2" Pan #2 Square Drive SDS 410 SS screw
	Rail Bracket to Rail	Two #10 x 2" Pan #2 Square Drive SDS 410 SS screw
Level - Bottom Rail, Bracket Base	Base to Post	Four #10 x 1-1/4" Pan #2 Square Drive, 302 SS screw <sup>1</sup>
	Rail Bracket to Base	Slip fit – No mechanical connection
Level - Bottom Rail Rail Bracket	Rail Bracket to Post	Slip fit – No mechanical connection
	Rail Bracket to Rail	Slip fit – No mechanical connection on 8' or less One #10 x 1" Pan #2 Square Drive SDS 410 SS screw <sup>1</sup> for 10' rail
Stair – Top Rail Upper Socket	Socket to Post	Two #10 x 2" Pan #2 Square Drive SDS 410 SS screw <sup>2</sup>
	Rail to Socket	Three #10 x 1" Pan #2 Square Drive SDS 410 SS screw <sup>2</sup>
Stair – Top Rail Lower Socket	Socket to Post	Two #10 x 2" Pan #2 Square Drive SDS 410 SS screw <sup>2</sup>
	Rail to Socket	Three #10 x 1" Pan #2 Square Drive SDS 410 SS screw <sup>2</sup>
Stair – Bottom Rail Upper Socket	Socket to Post	Two #10 x 2" Pan #2 Square Drive SDS 410 SS screw <sup>2</sup>
	Rail to Socket	Two #10 x 1" Pan #2 Square Drive SDS 410 SS screw <sup>2</sup>
Stair – Bottom Rail Lower Socket	Socket to Post	Two #10 x 2" Pan #2 Square Drive SDS 410 SS screw <sup>2</sup>
	Rail to Socket	Two #10 x 1" Pan #2 Square Drive SDS 410 SS screw <sup>2</sup>
Support Block <sup>3</sup> to Bottom Rail Premier and Select		One #10 x 3/4" Pan #2 Square Drive Tapping 302 SS screw
Support Block <sup>3</sup> to Bottom Rail PVC Composite		One #8 x 1" Pan #2 Square Drive SDS 410 SS screw and One #10 x 2-1/2" Square Drive Flat Head 18-8 SS screw

<sup>1</sup> Pre drill with 5/32 drill bit

<sup>2</sup> Pre drill with 1/8" drill bit

<sup>3</sup> Use one Support Block for 6-ft span and two Support Blocks for longer span

<sup>4</sup> See Applicable Characteristics Reviewed – 8 for additional post information